



SmartScope ZIP[®] Lite 250 | 300

SmartScope ZIP Lite 250 and Lite 300 models are compact benchtop, shop-floor capable systems with laser and touch probe capabilities. The ZIP Lite 250 and 300 also provide:

- **Rugged Construction** – Built with rigid granite base and column, hardened worktable, and heavy-duty mechanical slides.
- **Accurate Video Metrology** – AccuCentric[®] motorized zoom lens automatically compensates magnification for each zoom position.
- **Multisensor Versatility** – Optional non-contact sensors and touch probes.

High Performance Shop Floor Inspection and Measurement



Shown with optional Touch Probe.



SmartScope ZIP® Lite 250|300

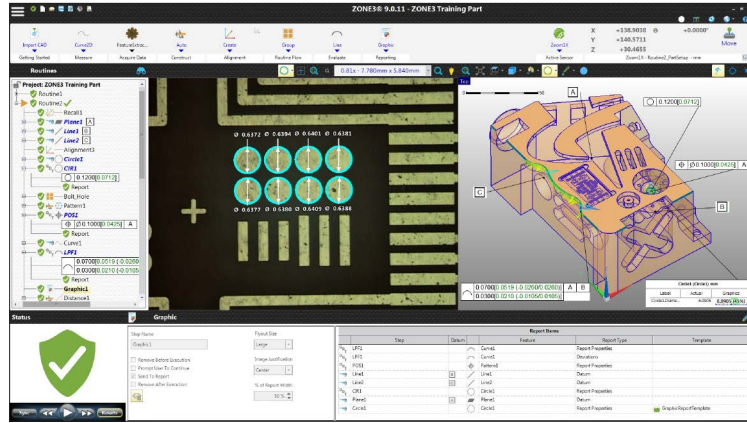

ZONE3® Metrology Software represents a totally new way of working with multisensor measurement systems, providing faster, easier, and more productive measurements.

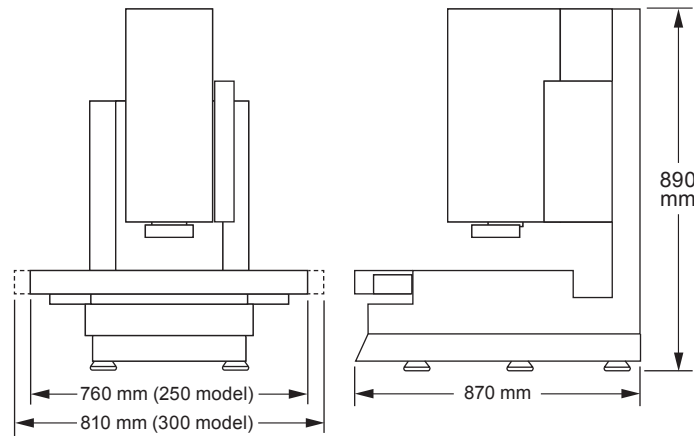

System Weight: 250 Model: 128 kg / 300 Model: 175 kg
Shipping Weight: 250 Model: 245 kg / 300 Model: 300 kg

		Standard	Optional
XYZ Travel	250	300 x 150 x 150 mm	
	300	300 x 300 x 150 mm	
XYZ Scale Resolution		0.5 µm	
Drive System		Stepper motors, X and Y; DC servo, Z and Zoom	
Worktable	250	Hardcoat anodized, with fixture holes, removable stage glass, 20 kg recommended max payload	
	300	Hardcoat anodized, with fixture holes, removable stage glass, 25 kg recommended max payload	
Rotary Axis			Miniature Servo Rotary (MSR™), MicroTheta Rotary (MTR™)
Optics*		AccuCentric® auto-compensating zoom, motorized; 1.0x lens; 1.0x adapter tube	Lens Attachments for 1.0x Lens: 0.5x, 0.75x, 1.5x, 2.0x Factory Installed Adapter Tubes: 0.67x, 2.0x
Illumination		Substage LED profile, coaxial LED surface, SmartRing™ LED ring light	
Metrology Camera**		Color digital metrology camera	2MP monochrome digital metrology camera
Field of View		6.6 mm x 5.0 mm (low zoom) to 1.2 mm x 0.9 mm (high zoom)	15.0 mm x 11.3 mm (0.67x tube, 1.0x lens, 0.5x attachment) to 0.33 mm x 0.25 mm (2.0x tube, 2.0x lens)
Working Distance		63 mm	Up to 85 mm (1.0x lens, 0.5x attachment)
Sensor Options			Tactile: TP20 or TP200 Touch Probe Non-Contact: DRS™ Laser
Software		<ul style="list-style-type: none"> Choice of ZONE3 Express or Measure-X metrology software QVI® Portal 	Metrology software: ZONE3 Prime, ZONE3 Pro Productivity software: MeasureFit® Plus, SmartFit® 3D, OGP® EVOLVE® Suite (Design, EVOLVE SPC, Manufacturing, SmartProfile®) Offline software: ZONE3, Measure-X
System Controller		Windows® based, with up-to-date processor and onboard networking/communication ports	
Controller Options			24" flat panel LCD monitor, or dual 24" flat panel LCD monitors, keyboard, 3-button mouse (or user supplied)
Power Requirements		100-120 VAC or 200-240 VAC, 50/60 Hz, 1 phase, 500 W	
Safe Operating Environment		15-30 °C, non-condensing	
Rated Environment		Temperature 18-22 °C, stable to ± 1 °C, max rate of change 1 °C / hour, max vertical gradient of 1 °C / meter; 30-80% humidity; vibration <0.001g below 15 Hz	
XY Area Accuracy		$E_2 = (2.2 + 6L/1000) \mu\text{m}$	
Z Linear Accuracy		$E_1 = (3.5 + 6L/1000) \mu\text{m}$	$E_1 = (2.5 + 5L/1000) \mu\text{m}$ (requires optional DRS Laser or Touch Probe)

Accuracy is evaluated with a QVI verification procedure where "L" is measured length in millimeters. Specifications apply within the rated environment. Standard optical specifications apply at the maximum optical magnification of the standard configuration. XY Accuracy applies with an evenly distributed load up to 5 kg in the standard measuring plane. The standard measuring plane is defined as a plane that is within 25 mm of the worktable surface. Depending on load distribution, accuracy at maximum payload may be less than standard.

*Lenses and lens attachments can be manually interchanged to change magnification and working distance. Adapter tubes can be manually changed to change magnification without impacting work distance, but unlike lens changes, adapter tube changes require optical system realignment and recompensation. **Monochrome camera only supported in ZONE3.



World Headquarters: Rochester, NY, USA • 585.544.0400 • www.ogpnet.com

OGP Shanghai Co, Ltd: Shanghai, China
86.21.5045.8383/8989 • www.smartscope.com.cn

OGP Messtechnik GmbH: Hofheim-Wallau, Germany
49.6122.9968.0 • www.ogpmesstechnik.de

Optical Gaging (S) Pte Ltd: Singapore • 65.6741.8880 • www.smartscope.com.sg